

STERLING

Water filter system pure, sparkling clean water

Sparkling clean
water, for a
fraction of the cost
of bottled water

Not only will you enjoy the pleasure and taste of filtered drinking water, but you will also appreciate the true flavours of coffee, tea and all other water based beverages.

Unlimited filtered water is always available on demand, for drinking, food preparation and cooking, by just using the lever on the dedicated chrome drinking water faucet.

Reduces

- Sediment
- Chlorine, Taste/Odour
- Giardia and Cryptosporidium



We supply all your kitchen needs. Tapware, sinks and accessories...
everything that you need for a modern functional kitchen.

Sterling Water Filters compliment every great new kitchen

STERLING

Water filter system pure, sparkling clean water

- Sparkling clean and fresh tasting water in your new kitchen
- Reduces sediment, organic matter, algae, dirt, rust and other particulate contaminants down to 0.5 micron in size
- Reduces offensive tastes and odours - chlorine
- Protection from parasitic cysts Giardia and Cryptosporidium
- Neat, compact and versatile design
- Does not remove fluoride
- Simple and quick Installation
- Supplied complete with all necessary plumbing fittings for easy installation

SIMPLE INSTALLATION

Installation is made simple with our Multi Function Control Valve, which provides:-

- Dual check backflow function
- Pressure limiting capability
- Anti-water hammer
- Flow restriction

Comes complete with plumbing installation kit and easy-to-follow installation instructions.

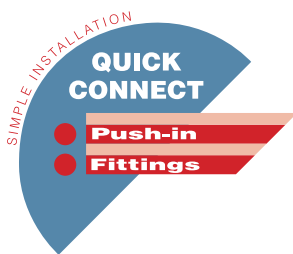

The unique Sterling Quick Change Replacement Cartridge requires **no tools** and is as simple as 1, 2, 3 to change.

- Align filter system head and cartridge label arrows
- Push into head
- Twist and seal

LIMITED ONE YEAR WARRANTY

The Sterling water filter system is designed to operate at a maximum pressure of 900kPa (130psi) and at a maximum temperature of 40°C. Sterling Water Filters warrants this purifier to be free from defects in material and workmanship for a period of one year from the date of purchase (*Warranty period does not apply to cartridge which is consumable). This warranty is expressly limited to the repair or replacement at our premises of any part or parts proving defective providing the purifier has been installed in accordance with our Installation Instructions, all relevant Plumbing Codes, the installation of an approved Pressure Limiting Device preceding the purifier, and the pressure and temperature do not exceed the limits stated herein. This warranty does not extend to mechanical damage caused during installation or use. Save insofar as they may be excluded by law, this warranty is given in lieu of all other expressed or implied warranties or conditions and Sterling shall in no event be held liable for damages or delays caused by defects and assumes no responsibility for unauthorised repairs.



When space is tight under your sink you can mount the Sterling Water Filter either vertically or horizontally

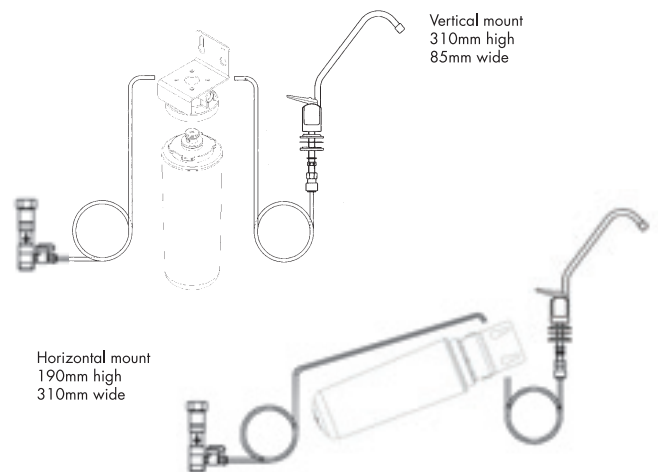

INSTALLATION TIPS

- Do not exceed operating parameters for temperature or pressure
- Do not install outside. Internal use only
- For cold water use only

Do not use with water that is microbiologically unsafe or of unknown quality without adequate disinfection before or after the system. Systems certified for cyst reduction may be used on disinfected water that may contain filterable cysts.

Sterling recommends regularly scheduled maintenance and replacement of the filter cartridge(s)

Processed under a quality system certified as complying with ISO 9001 by an accredited certification body.

Quality System
Quality Endorsed Company

For technical assistance and product support, phone our Help Line

1300 367 362

Available from: